

INTRODUCTION

The purpose of this Application Note is to provide a brief overview of the components and structure of GroWeather® and EnviroMonitor™ Industrial Systems and to discuss alternative ways in which the systems may be configured.

SYSTEM ORGANIZATION and INTERCONNECTS

Figures 1a,b, and c show the simplified schematics of the systems (assuming direct-wired WeatherLinks). Shown on each interconnect path are the connector designations and the maximum recommended cable length. Note that industrial-grade sensors have attached 16-foot (5-meter) cables; splices or Terminal Boxes will be required if longer sensor cables are needed.

The only differences among the systems are in the sets of sensors used and the data processing and display functions of the Console and Link.

Every system may include a Rain Collector, Temperature/Humidity Sensor or Temperature Sensor, Anemometer, and Solar Radiation Sensor (pyranometer). In addition --

- the **GroWeather System** may employ a second Temperature Sensor (usually for Soil Temperature) or a Leaf Wetness sensor.
- the **Health EnviroMonitor** may employ a UV Sensor.

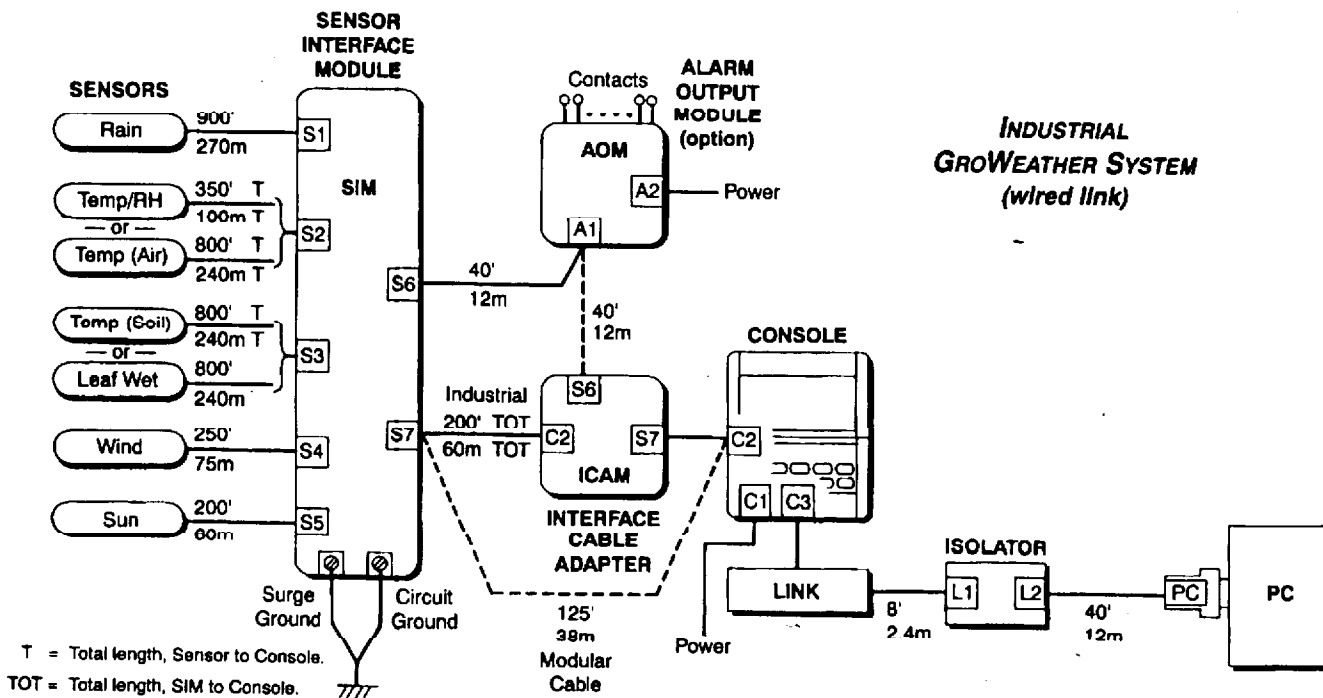

Figure 1a. GroWeather System Schematic

Sensor Interface Module (SIM). All sensors are connected to the SIM; connections are made via high-reliability screwless cage-clamp terminal blocks. The SIM provides surge protection (using micro-gap absorbers), EMI filtering (RC and LC low-pass filters), and multiplexing of the sensor signals. The SIM

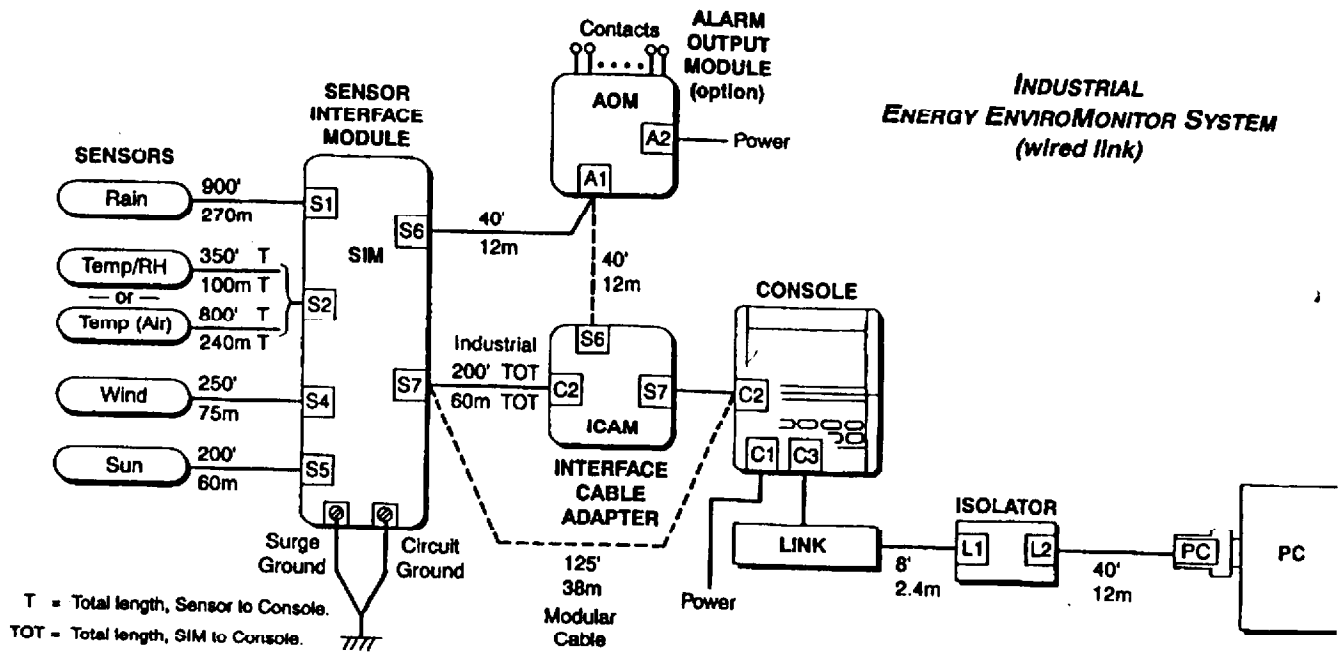

Figure 1b. Energy EnviroMonitor System Schematic.

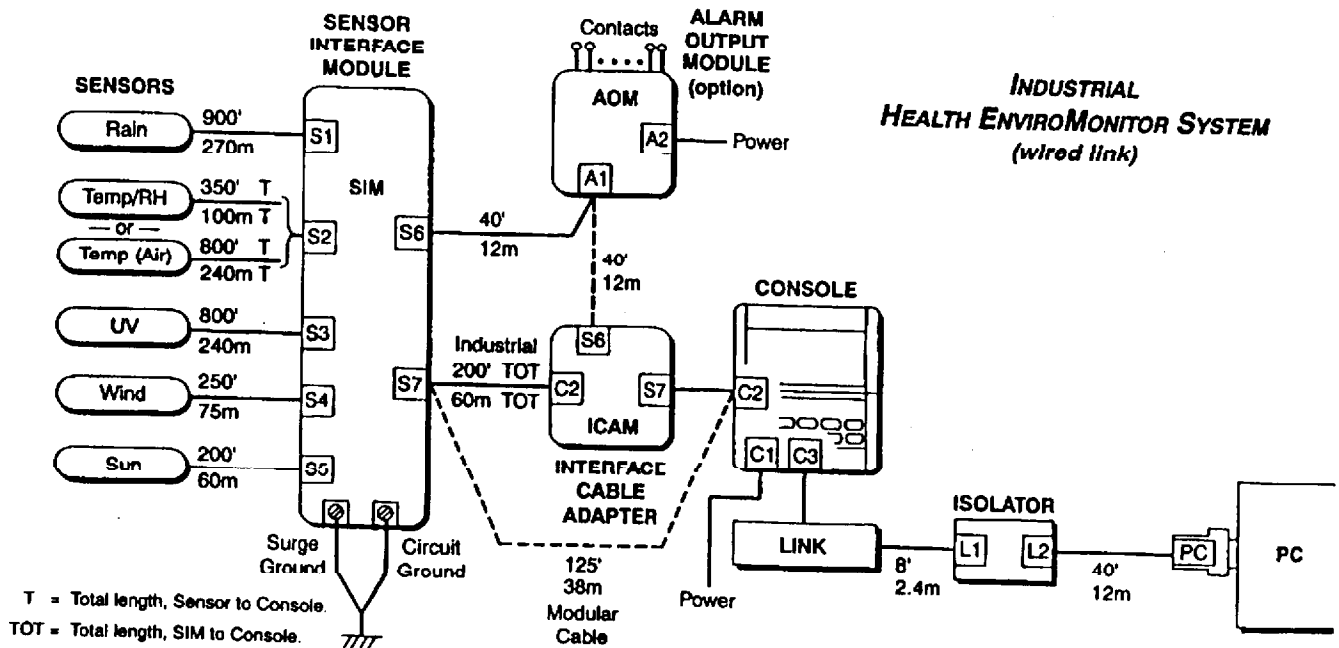

Figure 1c. Health EnviroMonitor System Schematic.

also provides a connection point for the Alarm Output Module (discussed below) and for the cable to the Console. Dual Console cable connectors permit use of either standard (modular) cable or shielded cable; if the SIM-to-Console cable is short, use of the provided 8-foot modular cable is suggested; for longer runs, use of Davis' Industrial cable is highly recommended. It comprises 22-gauge signal and power wires and an 18-gauge ground wire, as contrasted with the 26-gauge wire of the modular cable.

The SIM has two ground terminals: surge ground and circuit ground. The latter should usually be used as the one circuit ground for the entire weather station. The two ground terminals should be wired separately to a good earth ground connection. The terminals are screw-type.

Interface Cable Adapter Module (ICAM) option. The ICAM provides the transition from shielded cable to the modular cable required by the Console. (This function could also be accomplished by using a Terminal Box or other splicing method, but use of the ICAM is a bit more fool-proof, because industrial cable colors are labeled and a modular connector is provided). The ICAM also provides some EMI filtering and an alternative connection point for the Alarm Output Module.

Console. The Console performs A/D conversion of the sensor analog signals and scaling of the digital signals; it calculates and stores average, maximum, and minimum values, and it detects Alarm conditions. It contains the keypad and display for interaction with the user.

WeatherLink® option. In the GroWeather System the Link hardware module calculates ET. In all systems the module's function is to store long-term "archive" data and to transmit them to the computer, where WeatherLink software provides data management and display functions. Alternative transmission modes are listed below.

Alarm Output Module (AOM) option. The Console sends to the AOM information on the status of all Alarms. The AOM makes four of these (as user-selected at a patch-panel) available as isolated contact closures for connection to external equipment. The AOM may be connected to either the SIM or the ICAM; the cable and connectors are modular. Screwless terminal blocks are provided for the contact-closure outputs.

CABLE LENGTHS

Figure 1 indicates the recommended maximum lengths of cables. Two factors govern these recommendations:

Cable Resistance. Analog signals suffer some loss in accuracy when cable wire resistance becomes appreciable. The signals subject to these errors: Temperature, Leaf Wetness, Solar and UV Radiation.

Cable Capacitance. Digital signals are distorted when cable capacitance becomes too large. The signals subject to this: Relative Humidity, Rainfall, Wind Speed, and the Console's data to the AOM.

In addition, longer cable runs are more susceptible to noise pickup, but this should not be a governing factor when shielded cables are used.

Industrial attached sensor cables use 24-gauge wires. Extension cables are composed of 22-gauge wires, except for the 18-gauge ground wire in the SIM-Console cable.

GROUNDS

The weather station should be well-grounded. As a minimum, the two SIM ground terminals should be connected separately to a good earth ground with the provided 12AWG solid wires. The two 12-gauge wires may be connected to a ground rod; alternatively, they may be connected to the ground lug on the shelter, and it may be connected with heavier wire (8-gauge or larger is suggested) or copper strap to a ground rod.

WEATHERLINK ALTERNATIVES

Following is a summary list of the Link data channel characteristics:

- RS-232
- 2400 Baud (1200-Baud switch-selectable)
- Half-duplex
- Data-only (50 msec allowed for turn-time)
- CRC error-check
- Point-to-point, Master-slave.

The following are alternative transmission methods for uploading of WeatherLink data to and downloading of control commands and parameters from a Personal Computer:

Direct Wire. The Link as provided includes 48 feet of four-wire cable, Isolator, and Adapter for communication between the Link and the CommPort of the PC. The photo-coupled Isolator prevents problems caused by offsets between the grounds of the weather station and the computer.

Portable PC. To upload data or reset Console control parameters a portable (laptop) computer may be taken to the weather station and its CommPort connected to the Isolator with the provided adapter and cable.

Short-range Modems. If the Isolator and PC Adapter are replaced by a modem pair, communication via two-twisted-pair cable is feasible for distances up to several miles.

Radio Modems. Narrow-band or spread-spectrum radios may be used in the WeatherLink channel. Spread-spectrum or low-powered radios that require no FCC license provide communication distances from one-half to two miles. Narrow-band higher-power radios can provide ranges of many miles; they require FCC licenses (in the U.S.). The alternatives and some of the products available are discussed in Application Note 4: Wireless WeatherLink Communications.

Telephone. If a telephone and modem are available at the weather station and at the PC, Link communications can be achieved via the phone system. WeatherLink software supports autodialing and uploading of data from multiple stations.

Cellular Phone. If a modem and cellular telephone are installed at the weather station and a modem and phone are available at the PC, wireless Link communication can be achieved via the telephone system, as discussed in ApNote 4.

Satellite. When available, satellite communications will be discussed in ApNote 4.

PHYSICAL LAYOUT and SHELTER ALTERNATIVES

The following descriptions outline some of the alternatives available for the physical layout of the weather station.

INDOOR SYSTEM

In the simplest system configuration, the weather sensors are placed outside and the SIM and other components of the system are located inside the building.

FIELD INTERFACE SYSTEM

In this scheme the SIM is placed in a weather-tight shelter (the MultiPurpose Shelter is recommended) and located on the sensor mast, outside wall of a building, or other weather-exposed site, as shown in Figure 2. An advantage of this layout is that it permits the use of short sensor cables and requires the running of only the single SIM-Console cable through the building wall. The Console is located inside the building, where it is connected to AC power and is available for easy access by the user. The optional Alarm Output Module may be located either near the SIM or inside the building, where it is connected to the ICAM.

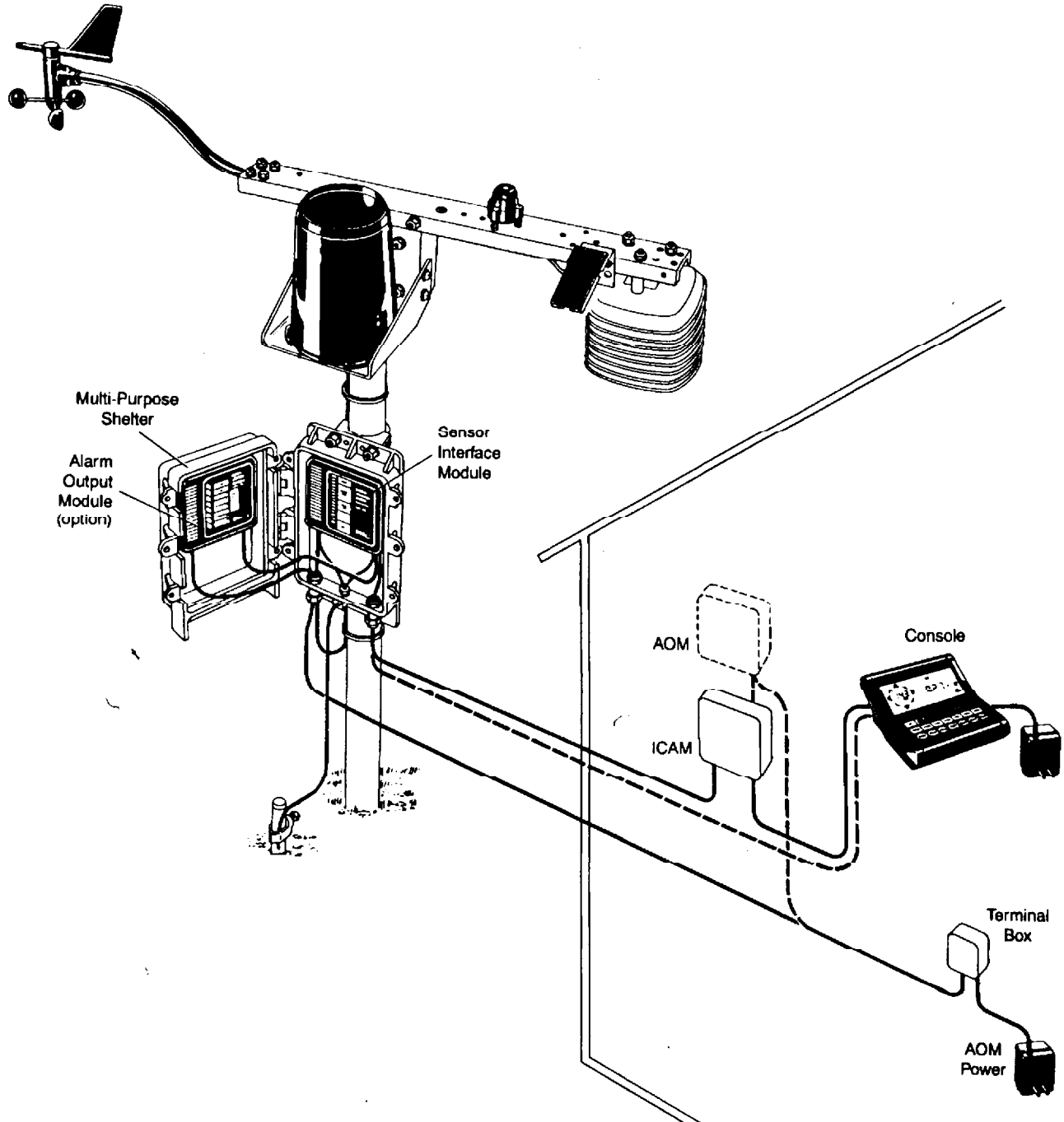

Figure 2. Field Interface System

FIELD STATION SYSTEM

The entire weather station is located in a weather-tight shelter on the sensor mast or other nearby location. If the station comprises only sensors, SIM, Console, Link, and Short-range Modem, the MultiPurpose Shelter is suitable; if an AOM, radio, phone modem, or battery is included, the Complete System Shelter is needed. The Link is connected to the computer via direct wire (if the cable length is less than 50 feet) or by telephone, short-haul modems, or wireless modems. Power is supplied to the Console via AC line, low-voltage cable, or solar panel, as discussed below. This configuration has the advantage of permitting the shortest possible cable lengths between sensors and Console, thus providing the best data accuracy. Figure 3 shows one version, this one using solar power and a radio WeatherLink.

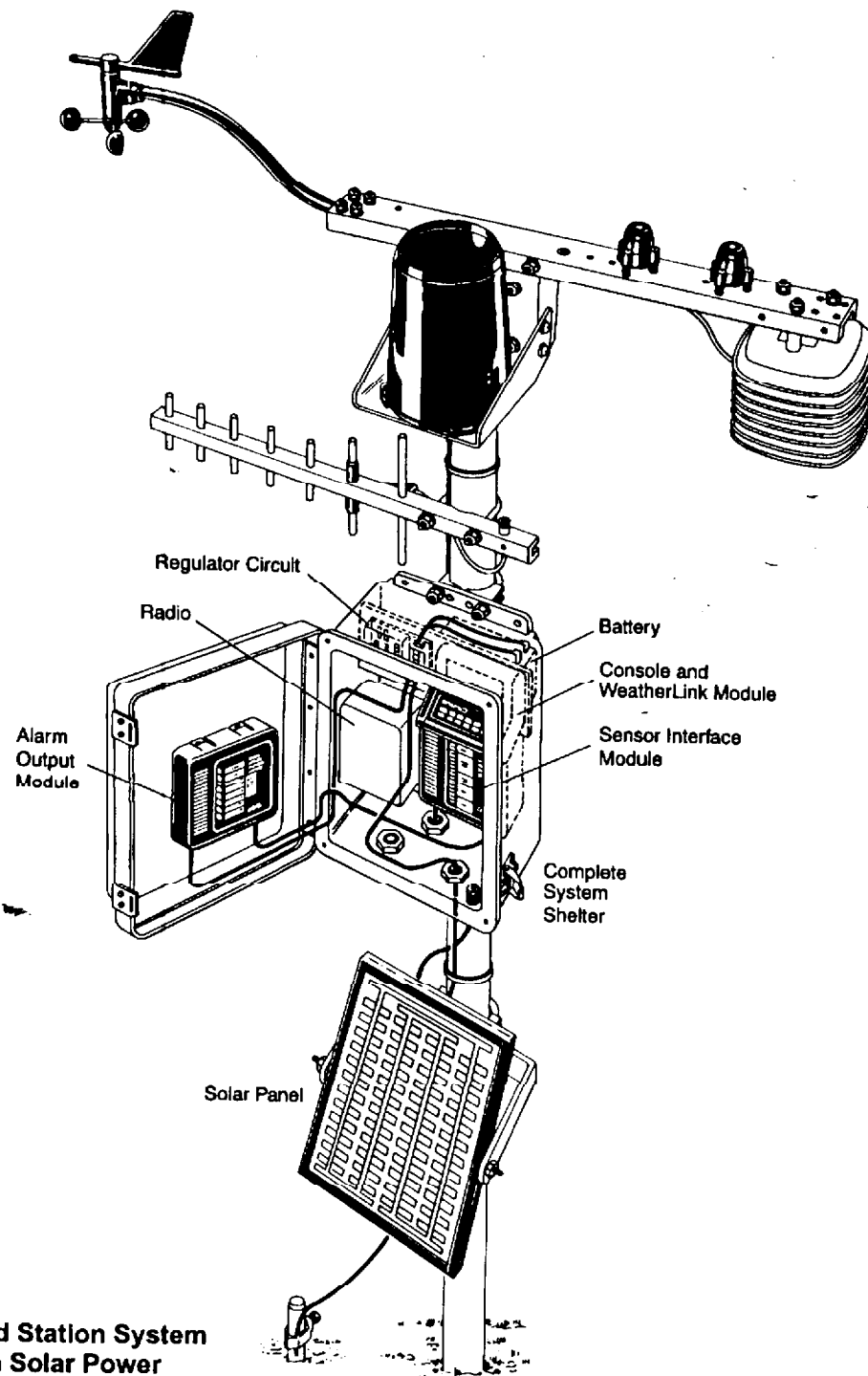

Figure 3. Field Station System with Solar Power and Radio

FIELD-BARN-OFFICE SYSTEM

This “stretched” configuration is a variation of the two preceding ones; one example is shown in Figure 4. The SIM is located in a weather-tight shelter (as in the Field Interface System). The SIM-console cable runs to a barn, shed, enclosure, or other intermediate shelter containing the Console and WeatherLink Module and the Alarm Output Module, if desired. From there, short-range or wireless modems connect the Link to the PC in the office. The Figure shows use of surge protectors on the Link cable. This may be desired for long runs in “lightning country;” it will not always be necessary, because the short-range modems incorporate both isolation and surge protection.

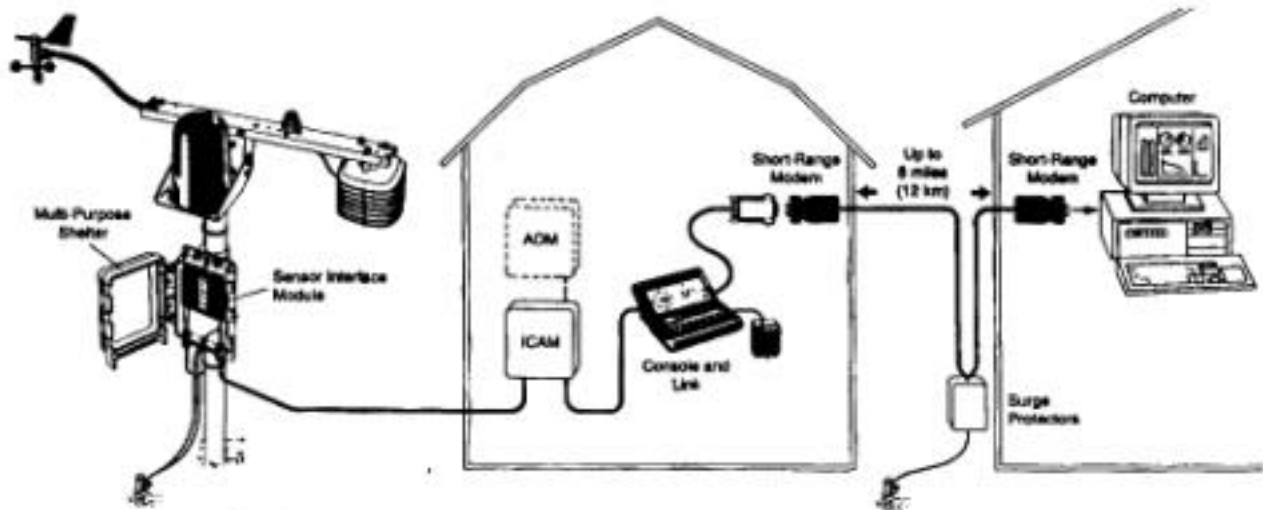

Figure 4. Field-Barn-Office System

SYSTEM POWER ALTERNATIVES

All weather stations receive their primary power at the power jack (C1) on the Console. The Console supplies power to the SIM and sensors via the SIM-Console cable. The AOM, if present, is powered separately; it may have its own Power Adapter or take power from a common supply via the split power cable provided.

The Console, SIM, Link, and sensors draw about 22 mA, typically (90 mA when the display illumination lamps are lighted). The voltage must be between +10 and +16 Volts DC. The station will operate with a supply voltage as low as 9 Volts, but the internal standby battery will begin to drain under this condition. The AOM draws 10 mA with only the LOAD LED lighted; each “contact” LED adds 10 mA.

Following are brief discussions of alternative means of supplying power to the station.

AC POWER at the STATION

All Davis weather stations are supplied with power adapters which plug into standard AC outlets and have 8-foot output cables. If AC line power can be made available in the vicinity of the Console, this should be done. Wiring and enclosures are the responsibility of the user and should, of course, be done according to all applicable codes. If AC line power is not available, one of the following alternatives may be used.

LOW-VOLTAGE DC CABLE

DC Power may be wired to the Console by cutting the Power Adapter's cable and splicing in a length of cable. Suggested maximum lengths (assuming display illumination lamps are not on) are given in Table 1.

Table 1. Maximum Length of Station Power Cable

Station Power Cable Wire Size		Max. Recommended Length		Note
Davis #7884		1200 feet	360 meters	Two 22-gauge (0,76mm) for each "wire."
24 AWG	0,60 mm	360	108	One pair.
22	0,76 mm	600	180	"
20	0,96 mm	900	270	
18	1,21 mm	1500	450	"

SOLAR POWER

A 5-Watt solar panel and 12-Volt battery combination will power the station under most conditions. The Davis #7708 Solar Power Kit uses a 10-Watt panel to provide a good margin of safety.

BATTERY

Some users of Davis weather stations as remote monitors carry power to the stations in the form of 12-Volt automobile batteries. They visit each station every two months to upload data and exchange the battery for a charged one. A typical car battery can power the system for more than six months.

HEATER POWER

Heaters may be installed in the Rain Collector, the MultiPurpose Shelter, or the System Shelter. Each heater element draws 1 Amp at 24 VAC, so the heater transformer must be powered from the AC line. The following chart gives maximum recommended lengths of extended transformer output cables.

Table 2. Maximum Length of Low-voltage Heater Power Cable

Heater Cable Wire Size		Max. Recommended Length		Note
Davis #7884		120 feet	36 meters	Two 22-gauge (0,76mm) for each "wire."
20 AWG	0,96 mm	100	30	One pair.
18	1,21 mm	175	52	"
16	1,49 mm	250	75	"

DAVIS 
Davis Instruments

3465 Diablo Avenue, Hayward, CA 94545 U.S.A.
 Phone: 510-732-9229 • Fax: 510-732-9188
 sales@davisnet.com • http://www.davisnet.com